

For safe measurement and control in hazardous areas

MTL700 SERIES

Shunt-diode safety barriers

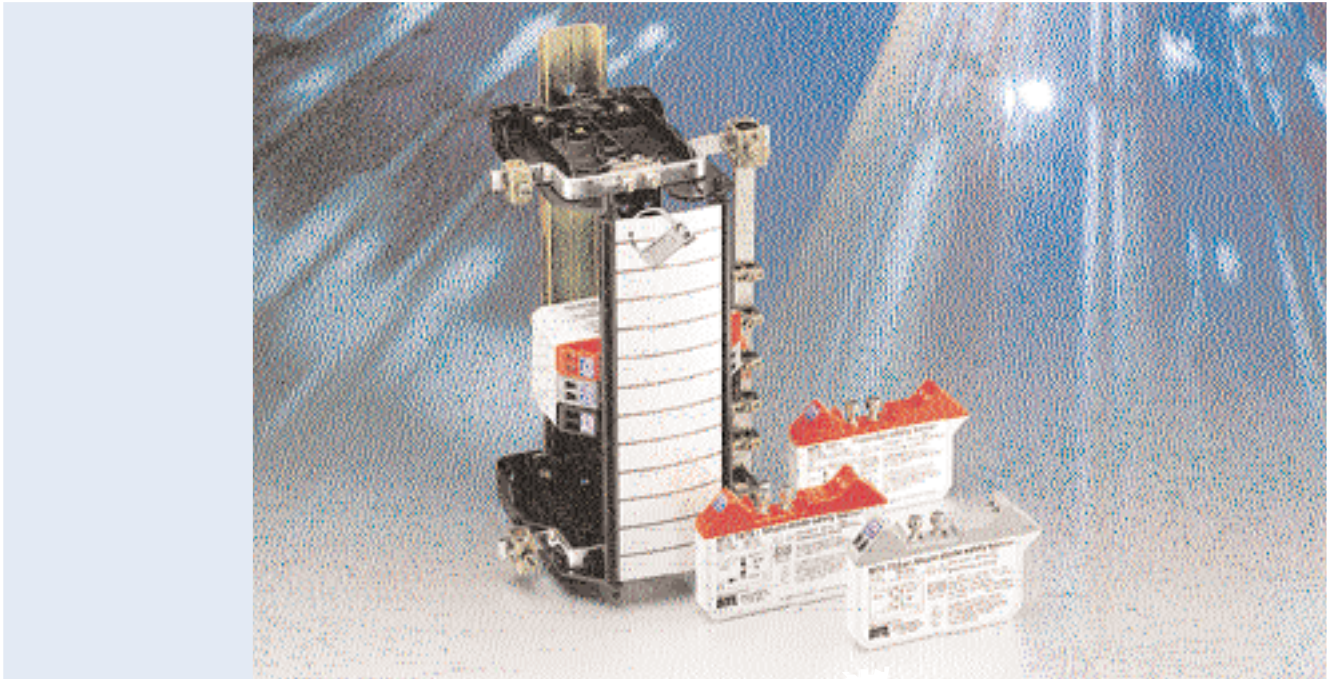

- ◆ **1 or 2 channels in same slim package**
- ◆ **Electronic protection prevents blown fuses**
- ◆ **Higher-power barriers for group IIC and IIB gases**
- ◆ **All models short-circuit proof**
- ◆ **Stay-put tagging & cable-screen earthing**
- ◆ **Certified to worldwide standards**

MTL700 Series shunt-diode safety barriers are 1- or 2-channel devices which pass an electrical signal in either direction without shunting it, but limit the transfer of energy to a level that cannot ignite explosive atmospheres. Connected in series with the signal transmission lines on a process plant, they protect hazardous-area wiring and equipment against faults occurring in the safe area, and enable a wide range of measurement and control operations to be carried out simply and inexpensively by intrinsically safe techniques. Conventional wiring and, frequently, standard transducers can be employed in the hazardous area, and can be worked on for maintenance or calibration purposes without further precautions. Safe-area equipment needs no certification and can be modified or extended as required.

Applications include the protection of installations containing 'simple' uncertified devices such as thermocouples, switches, and resistive sensors, or separately certified 'energy storing' or 'voltage producing' apparatus, for example ac sensors,

transmitters, and current-to-pneumatic (I/P) converters. All 'simple' devices can be used in areas of continuous hazard: 'energy-storing apparatus' is certified for use in a particular 'zone' or 'division'. MTL700 Series barriers give protection in all normally occurring explosive atmospheres, including all mixtures with air of flammable gases, vapours, dusts, fibres and flyings.

Essential features of the MTL700 Series are the self checking 'as-you-mount-it' earthing via two studs directly to nickel-plated brass or copper busbar. The earth connection is on top of the unit, allowing easy inspection, installation and removal. The shape of the barrier has been designed for easy wiring, while the common (14.5 mm) space requirement of both 1- and 2-channel units simplifies planning or alteration of installations of all sizes. The terminals of the barrier are angled for easy access and accept field wiring directly, making a second set of terminals unnecessary. The busbar is insulated for separate earthing, to eliminate the danger of invasion by fault currents.

Overvolt protection in several models permits their use with unregulated power supplies.

MTL700P shunt-diode safety barriers deliver more power into hazardous areas. Two types of MTL700P barriers exist. The first type (two barriers) is designed specifically for group IIB gases, which permits considerably more power. The other (seven barriers) takes advantage of a change in the BSI's interpretation of the European standard EN 50020 (bringing it into line with that of other European certifying authorities and also corresponding with the requirements of North American standards). This interpretation removes the requirement to increase the value of the safety voltage by 10% before determining the maximum allowed current from the published ignition curves. This allows the

end-to-end resistance of the barrier to be reduced, with the result that it is possible to supply more power into a IIC gas group area. Because of the higher power levels available, it is important when considering the use of MTL700P barriers to check the compatibility of the electrical safety parameters of the field equipment (such as transmitters and solenoid valves) with those of the barriers to make sure the combination is safe. In addition, with the barriers designed for IIB gas group applications, the overall gas classification of the system also needs checking. The example below shows an MTL707P IIB barrier used with IIC field equipment in a IIB gas group area. This gives an overall system classification of group IIB despite the group IIC certification of the transmitter. The MTL700P barriers feature cable parameters which do not introduce loop design problems for the majority of applications.

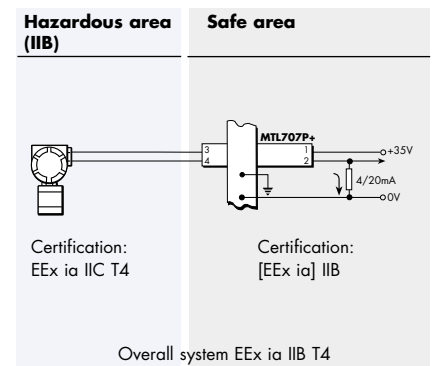

References. The following documents are available for further information on MTL700 Series barriers:

- AN9007 *A user's guide to shunt-diode safety barriers*
- INM700 *The MTL700 Series instruction manual*
- Technical papers TP1064, TP1082, TP1083, TP1106

SPECIFICATIONS

'Key' barriers shown in blue
For notes 1 to 7 see 'Terminology' (later in this section)

Model No.	Safety description ¹			Polarities available ²			Application	Basic circuit	Max. end-to-end resistance ³	Vwkg at 10(1)µA ⁴	Vmax ⁵	Fuse rating ⁶			
	V	mA	mA	+	-	ac							Hazardous	Safe	V
702 706 707 707P† 708	25 28 28 28 15 28	200 300 300 diode 164 300	125 93 93 - 171 93	- - - - - -	- - - - - -	- - - - - -	Transmitters Transmitters Switches Transmitters, switches, controller outputs Solenoids, alarms, LEDs, switches		- - - See additional specification -	- - - - - -	35 35 35 - 35 35	See 'How the work'			
710 710P 715 715P 722 722P 728 728P 729P†	10 10 15 15 22 22 28 28 28	50 33 100 50 150 101 300 300 234 164	200 300 150 291 147 213 93 93 119 171	- - - - - - - - - -	- - - - - - - - - -	- - - - - - - - - -	6V dc & 4V ac systems 8V dc systems 12V systems 12V dc systems 18V dc systems 18V dc systems Controller outputs, solenoids Transmitters Controller outputs, solenoid valves Controller outputs, solenoid valves			85 42 155 60 185 121 340 340 253 184	6.0 8.0 12.0 12.5 19.0 18.5 25.5 25.5 ^b 24.5 24.5	6.9 ^c 9.2 13.0 13.8 20.2 20.0 26.6 26.6 ^d 26.0 26.0	50 200 100 200 50 100 50 50 100 100		
751 755	1 3 3	10 10 10	100 100 300 300	- - -	- - -	- -	Active dc & ac sensors (low impedance receivers) Resistance temperature detectors				20 20 18.0^a 18.0^a	0.3 0.3 (0.6) (0.6)	2.0 2.0 3.6 3.6	250 250 250 250	
758 761 761P 764 766 766P 767 768 779 796	7.5 7.5 9 9 9 12 12 12 15 15 22 22 28 26 20	10 10 90 90 350 350 1k 1k 150 150 75 75 100 100 300 300 300 87 390	750 750 100 100 25 25 12 12 80 80 157 157 150 150 93 93 87 51	- - - - - - - - - - - - - - - - - -	- - - - - - - - - - - - - - - - -	- - - - - - - - - - - - - - - - -	Gas detectors Strain-gauge bridges Strain-gauge bridges Strain-gauge bridges 12V dc systems 18V dc systems Controller outputs Vibration probes (MTL796 negative)					18 18 145 145 384 384 1075 1075 185 185 93 93 155 155 185 185 340 340 340 435	6.0 6.0 6.0 6.0 7.0 7.0 10.0 10.0 10.0 10.0 9.8 9.8 12.0 12.0 19.0 19.0 25.5 25.5 23.5 17.5	7.0 7.0 7.5 7.5 8.1 8.1 10.7 ^e 10.7 ^e 11.2 11.2 11.3 11.3 13.0 13.0 20.2 20.2 26.6 26.6 24.6 18.7	200 200 100 100 50 50 50 50 50 50 100 100 100 100 50 50 50 50 50 50
760 765 772 778	10 10 15 15 22 22 28	50 50 100 100 300 300 600	200 200 150 150 73 73 47	- - - - - - -	- - - - - - -	- - - -	Active dc & ac sensors Thermocouples 2-wire dc & ac systems					85 85 135 135 340 340 665	6.0 6.0 12.0 12.0 18.0 18.0 24.0	7.4 7.4 13.2 13.2 19.7 19.7 25.7	50 50 50 50 50 50 50
786	28 28	600 diode diode	47 - -	- - -	- - -	- -	Signal returns						665 2.2V+30 2.2V+30	24.0 25.5 25.5	25.7 26.6 26.6
787 787S 787SP	28 28 28	300 diode 300 diode 234	93 - 93 - 119	- - -	- - -	- - -	Controller outputs, switches Transmitters Controller outputs, switches Transmitters, controller outputs switches						340 2.2V+30 340 0.9V+20 258	25.5 25.5 25.5 25.5 24.5	26.6 26.6 26.6 26.6 26.5
788 788R	28 10 28	300 50 300	93 200 93	- - -	- - -	- -	Transmitters						340 85 340 85	25.5 6.0 25.5 6.0	26.6 6.9 26.6 6.9
791	10 11 11	50 51 51	200 216 216	- - -	- - -	- -	31.25kbit/s fieldbus installations						62.6 62.6	10V (at 50µA) -10V (at 50µA)	10.5 -10.5
799	Dummy barrier for securing cables for future installations – takes hazardous-area circuits to earth														

a: Tolerance ±0.15 at 20°C, channels track within 0.15 from -20 to +60°C.
 b: ac version 24.5V.
 c: ac version 7.4V.
 *Diagrams show positive versions. All diodes reversed on negative versions. Additional diodes fitted on ac versions.
 Patents for MTL787S: UK Patent No. 2210522, USA Patent No. 4860151; Patents for MTL707P: UK Patent Nos. 2210521, 2210522; USA Patent No. 4860151; Patents for MTL787SP: UK Patent No. 2210522; USA Patent No. 4860151
 d: ac version 26.1V.
 e: ac version 11.2V.
 †: Gas group IIB (CENELEC), C (N America).

HOW THEY WORK

All MTL700 Series barriers are based on the same simple principle. Each channel contains two stages of pulse-tested Zener or forward-connected diodes and an 'infallible' terminating resistor. In the event of an electrical fault in the safe area, the diodes limit the voltage that can reach the hazardous area and the resistor limits the current. A fuse protects the diodes, and the two stages of voltage limitation ensure continued safety if either stage should fail. No active output-current limiting circuits are employed. All models are certified 'ia' for all zones and 'IIC' for all explosive atmospheres (except MTL707P+ and MTL729P+, 'ia' 'IIB').

TERMINOLOGY

1. Safety description

The safety description of a barrier, eg '10V 50 200mA', refers to the maximum voltage of the terminating Zener or forward diode while the fuse is blowing, the minimum value of the terminating resistor, and the corresponding maximum short-circuit current. It is an indication of the fault energy that can be developed in the hazardous area, and not of the working voltage or end-to-end resistance.

2. Polarity

Barriers may be polarised + or -, or non-polarised ('ac'). Polarised barriers accept and/or deliver safe-area voltages of the specified polarity only. Non-polarised barriers support voltages of either polarity applied at either end. An exception to this is the MTL791 Fieldbus barrier which has one positive and one negative channel.

3. End-to-end resistance

The resistance between the two ends of a barrier channel at 20°C, ie of the resistors and the fuse. If diodes or transistors are present, their voltage drop (transistors ON) is quoted in addition.

4. Working voltage (Vwkg)

The greatest steady voltage, of appropriate polarity, that can be applied between the safe-area terminal of a 'basic' barrier channel and earth at 20°C for the specified leakage current, with the hazardous-area terminal open circuit.

5. Maximum voltage (Vmax)

The greatest steady voltage, of appropriate polarity, that can be applied continuously between the safe-area terminal of any barrier channel and earth at 20°C without blowing the fuse. For 'basic' barriers, it is specified with the hazardous-area terminal open circuit; if current is drawn in the hazardous area, the maximum voltage for these barriers is reduced. The 'ac' channels of 'basic' barriers and most channels of overvoltage-protected barriers withstand voltages of the opposite polarity also – see circuit diagrams.

6. Fuse rating

The greatest current that can be passed continuously (for 1000 hours at 35°C) through the fuse.

7. Star connection

In star-connected barriers, the two channels are interlocked such that the voltage between them cannot exceed the working voltage, Vwkg: this allows for higher cable capacitance or inductance.

8. Maximum safe-area voltage (U_m)

The maximum permissible safe-area voltage (U_m) for MTL700 Series barriers is 250V ac/dc.

GENERAL SPECIFICATION

Ambient temperature and humidity limits

-20 to +60°C continuous working
-40 to +80°C storage
5-95% RH

Leakage current

For 'basic' barriers with a working voltage of 5V or more, the leakage current decreases by at least one decade per volt reduction in applied voltage below the working voltage, over two decades. For the MTL755 it decreases by at least one decade for a 0.4V reduction in applied voltage.

Terminations

Terminals accommodate conductors up to 4mm² (12AWG)
Hazardous-area terminals are identified by blue labels.

Colour coding of barrier top

Grey: non-polarised
Red: positive polarity
Black: negative polarity
Black (red label for safe-area terminals): positive supply, negative to transmitter (MTL706)
White: dummy barrier, MTL799

Weight

125g approx

Mounting and earthing

By two integral M4 x 9 tin-lead plated steel fixing studs and stainless steel self-locking nuts (provided).

EMC compliance

EN 50 081-2/EN 50 082-2, generic emission/immunity standards. These refer to appropriate IEC/CISPR standards. (MTL707P+ and MTL702+ are not CE marked)

DIMENSIONS (mm)

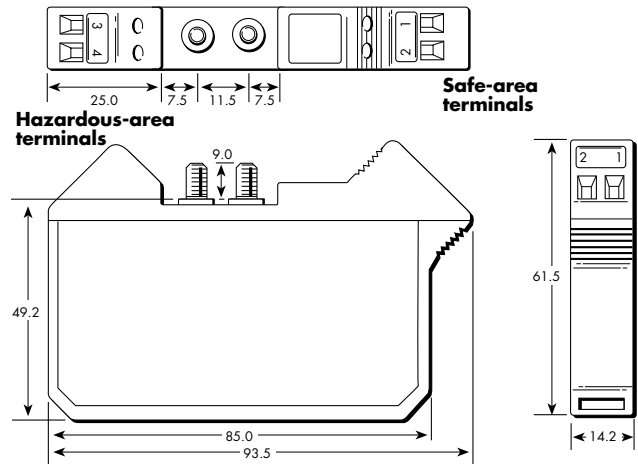

KEY MTL700 SERIES BARRIERS SUMMARISED

TYPE	APPLICATION	KEY BARRIER	
Analogue input (low-level)	Resistance temperature detectors Thermocouples, ac sensors	755ac 760ac	
Analogue output	Controller outputs, one line earthed Controller outputs, neither line earthed	728+ 787S+	
		dc power supply	
		26.0V	20-35V
Analogue input (high-level)	Transmitters, 2-wire, 4/20mA	787S+	706+
Digital (on/off) input	Switches	787S+	707+
Digital (on/off) output	Solenoids, alarms, LEDs	728+	708+

Patents for MTL706+, 707+, 708+, 787S+

OVERVOLT-PROTECTED BARRIERS

MTL702+ for 2-wire 4/20mA transmitters

The MTL702+ is a 1-channel shunt-diode safety barrier, with built-in electronic overvoltage protection, for energising a 2-wire 4/20mA transmitter in a hazardous area. It is powered from a positive supply of 20–35V dc and delivers a 4/20mA signal into an earthed load in the safe area. It is proof against short circuits in the field and in the safe area, and is highly accurate. Like all barriers, the MTL702+ will pass incoming communication signals of any frequency from a 'smart' transmitter, but inherently it cannot pass any such signals in the outgoing direction.

Since the MTL702+ has no return channel for energising the load, the entire output of the single '25V' channel is available to power the transmitter, providing high output capability. This channel is positively polarised, and the safe-area signal is derived from the current that flows through it by means of a built-in 'current-mirror' amplifier, with unity current gain, which repeats the current in a separate circuit in the safe area.

To prevent any leakage through the Zener diodes and maximise the output voltage available at 20mA, the voltage applied to the barrier section is held constant at a suitable reference value by a comparator amplifier and regulator. A separate circuit limits the current to protect the fuse in the event of a short circuit in the hazardous area.

With a 22V supply, the MTL702+ will deliver 14V at 20mA for the transmitter and lines and a quite exceptional 17V for the load, both voltages being increased by 2V if the supply is at least 24V. The maximum consumption in normal operation is 60mA.

BASIC CIRCUIT

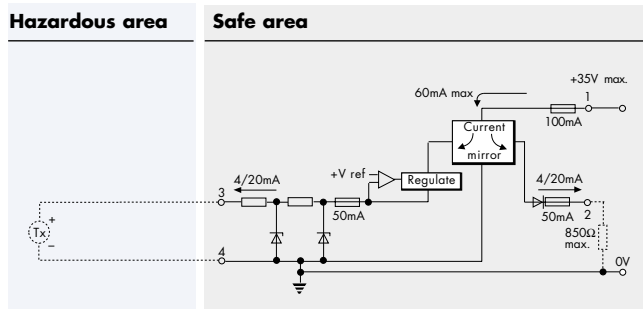

ADDITIONAL SPECIFICATION

Supply voltage

20 to 35V dc, positive w.r.t. earth

Voltage available for transmitter and lines (at 20mA)

$(V_{\text{supply}} - 8V)$, limited at 16V

Voltage available for load (at 20mA)

$V_{\text{supply}} - 5V$

Load resistance

850 maximum

Output impedance to load

> 1M

Calibrated accuracy (at 20°C with 250 load)

0.05% of maximum output, including non-linearity and hysteresis

Zero temperature drift

< 0.005% of maximum output per °C

Span temperature drift

< 0.005% of maximum output per °C

Supply current

8 to 40mA + 10mA max. at 20V

8 to 40mA + 20mA max. at 35V

OVERVOLT-PROTECTED BARRIERS

The MTL702+, 706+, 707+, 707P+ and 708+ have built-in overvoltage protection, allowing their use with unregulated power supplies. In many applications, eg, sensor inputs or controller outputs, there is insufficient power available to blow the barrier fuse and this additional protection is not necessary. However, where the barrier is connected to a power supply, eg, for energising transmitters, switches, solenoids or local alarms, overvoltage protection allows the barriers to be used with unregulated supplies up to 35V dc and also gives protection against faulty wiring during commissioning.

MTL706+ for 'smart' 2-wire 4/20mA transmitters

UK Patent No. 2205699

USA Patent No. 4967302



European Patent (Germany, France, Italy) No. EP 0 294 139 B1

The MTL706+ is a 1-channel shunt-diode safety barrier, with built-in electronic overvoltage protection, for energising a 2-wire 4/20mA transmitter in a hazardous area. It is powered from a positive supply of 20–35V dc and delivers a 4/20mA signal into an earthed load in the safe area. It is proof against short circuits in the field and in the safe area and is extremely accurate. The MTL706+ will pass incoming communication signals up to 10kHz from a 'smart' transmitter, while in the outgoing direction it will pass signals of any frequency likely to be encountered.

Since the MTL706+ has no return channel for energising the load, the entire output of the single '28V' channel is available to power the transmitter, providing high output capability. This channel is negatively polarised, and the safe-area signal is in fact the very current that returns through it from the hazardous area, the novel circuit being energised by a built-in floating dc supply derived from the external dc source of power.

To prevent any leakage through the Zener diodes and maximise the output voltage available at 20mA, the floating supply is given a rising voltage/current characteristic. This is achieved by monitoring the 4/20mA current, an arrangement which allows all-frequency communication in both directions. A separate circuit limits the current to protect the fuse in the event of a short circuit in the hazardous area.

With a 22V supply, the barrier will deliver 15V minimum at 20mA for the transmitter and lines and consumes less than 40mA in normal operation.

Note: the MTL706+ supersedes the MTL705+, which was similar in basic performance but did not pass outgoing communication signals below about 1kHz.

BASIC CIRCUIT

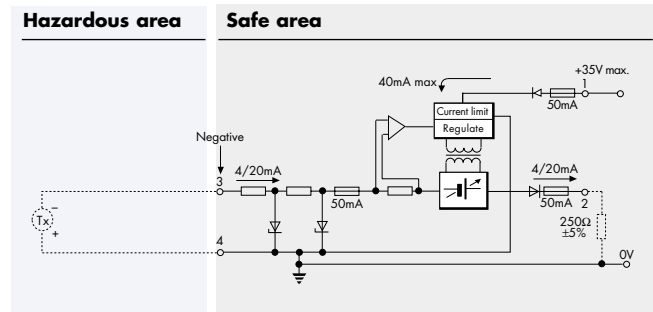

ADDITIONAL SPECIFICATION

Supply voltage

20 to 35V dc, positive w.r.t. earth

Output current

4 to 20mA

Voltage available for transmitter and lines

15V minimum at 20mA with 22V supply

15.5V typical at 20mA with 24V supply

Note: voltages are negative w.r.t. earth

Load resistance

250 ±5% (can be greater if reduced transmitter voltage is acceptable)

Accuracy

±2µA under all conditions

Supply current

35mA typical at 20mA with 24V supply

40mA maximum at 20mA with 35V supply

OVERVOLT-PROTECTED BARRIERS

(continued)

MTL707+ for switch inputs

UK Patent Nos. 2245439, 2210521
European Patent No. EP 0 310 280 B1



The MTL707+ is a 2-channel shunt-diode safety barrier similar to the MTL787+ but with built-in electronic overvoltage protection. It is intended primarily for safeguarding a hazardous-area switch controlling a relay, opto-coupler or other safe-area load from an unregulated dc supply in the safe area.

The outgoing channel accepts supply voltages up to +35V and is protected against reverse voltages: the return channel is unaffected by voltages up to +250V.

In normal operation the protection circuit introduces only a small voltage drop and shunts less than 1mA to earth, so its overall effect is minimal. If the supply voltage exceeds about 27V, however, causing the Zener diodes to conduct – or if the safe-area load has a very low resistance – the supply current is limited automatically to 50mA, protecting the fuse and power supply and enabling the loop to continue working.

BASIC CIRCUIT

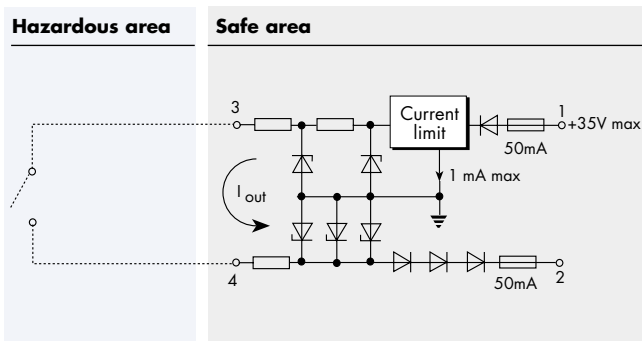

ADDITIONAL SPECIFICATION

Supply voltage (V_s)

10 to 35V dc, positive w.r.t. earth

Output current (I_{out})

Up to 35mA available

Maximum voltage drop (at 20°C, current not limited)

$I_{out} \times 370 + 1.5V$, terminal 1 to 3

$I_{out} \times 50 + 2.1V$, terminal 4 to 2

Supply current

$I_{out} + 1mA$ max, $V_s < 26V$

Limited at 50mA, $V_s > 28V$ or low load resistance

MTL707P+ for switch inputs, IIB gases

The MTL707P+ is a two-channel shunt-diode safety barrier similar to the MTL787SP+, but is designed for use with group IIB gases and features built-in electronic overvoltage protection allowing use with unregulated power supplies up to 35V dc. It is intended primarily as a low cost solution for driving IIB certified 2-wire 4/20mA transmitters, but can also be used with controller outputs with current monitoring, solenoid valves and switches. To protect the fuse and enable the loop to continue working, the supply current is limited automatically at 50mA should the output be short-circuited or excess voltage applied.

BASIC CIRCUIT

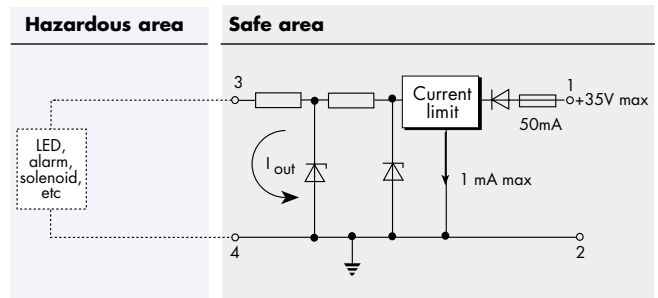

ADDITIONAL SPECIFICATION

Supply voltage – channel 1 (V_s)

10 to 35V dc positive with respect to earth

Output current – channel 1 (I_{out})

Up to 35mA available

Maximum voltage drop (at 20°C, current not limited)

$I_{out} \times 200 + 0.2V$, terminals 1 to 3

$I_{out} \times 18 + 1.3V$, terminals 4 to 2

Supply current

$I_{out} + 2mA$ max, $V_s < 25V$

Limited at 50mA, $V_s > 28V$ or low load resistance

MTL708+ for switched outputs

UK Patent No. 2210521

European Patent No. EP 0 310 280 B1



The MTL708+ is a 1-channel shunt-diode safety barrier similar to the MTL728+ but with built-in electronic overvoltage protection. It is intended primarily for safeguarding solenoids, alarms, light-emitting diodes or other hazardous-area loads controlled by a safe-area switch from an unregulated dc supply in the safe area.

The barrier accepts supply voltages up to +35V and is protected against reverse voltages.

In normal operation the protection circuit introduces only a small voltage drop and shunts less than 1mA to earth, so its overall effect is minimal. If the supply voltage exceeds about 27V, however, causing the Zener diodes to conduct – or if the hazardous-area load has a very low resistance – the supply current is limited automatically to 50mA, protecting the fuse and power supply and enabling the loop to continue working.

BASIC CIRCUIT

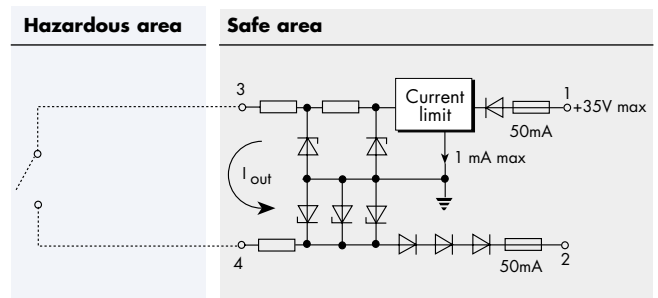

ADDITIONAL SPECIFICATION

Supply voltage (V_s)

10 to 35V dc, positive w.r.t. earth

Output current (I_{out})

Up to 35mA available

Maximum voltage drop (at 20°C, current not limited)

$I_{out} \times 370 + 1.5V$, terminal 1 to 3

Supply current

$I_{out} + 1mA$ max, $V_s < 26V$

Limited at 50mA, $V_s > 28V$ or low load resistance

BARRIERS FOR SENSORS

ANALOGUE INPUTS, LOW LEVEL

Thermocouples

The preferred barrier for thermocouples is the MTL760ac, whose 2-channel non-polarised design retains the 'earth-free' nature of the signal. Provided that the receiver's input circuit floats, the combination rejects common-mode ac and dc interference up to at least 6V and is unaffected by earth faults on the primary element. Even if the receiver's circuit is tied to its '0V' rail, the use of a 2-channel barrier takes the worry out of earthing. To eliminate errors due to thermal emfs, the compensating cable should be continued from the barrier to the receiver. For moving coil or other low resistance receivers, use the MTL751 (40) or the MTL755ac (36) if the resistance of the MTL760 (170) is unacceptable.

USA regulations permit the thermocouple to be earthed on the assumption that the barrier will not conduct, but Europe and other 'IEC countries' assume that it may do so. In these countries either the thermocouple and its cables must be insulated to withstand 500V, Fig. 1; or the earth loop must be broken by an isolating transmitter, Fig. 2, or by one of the isolating interface devices in the MTL2000, 3000, 4000 or 5000 Series.

Photocells, ac sensors, flowmeters

Similar arguments apply, and the MTL760ac is recommended, Fig. 3. Any other 2-channel non-polarised barrier that will handle the voltage would be suitable. All MTL barriers of this type transmit signals up to a few kHz. At higher frequencies the self capacitance of the Zener diodes – around 1000pF – may attenuate the signal. No certification is required for sensors generating less than 1.2V, 0.1A, 20µJ and 25mW. In practice this includes all photocells, but some ac sensors may have significant inductance and require to be designed and certified for use in hazardous areas.

Resistance temperature detectors

For 3-wire circuits with a floating bridge, the most economical solution is provided by the MTL755ac 2-channel barrier, Fig. 4. The two leads from the bridge arms are protected by the barrier, while the third (supply) lead is earthed at the busbar. The MTL755ac has a low end-to-end resistance of only 18.0 per channel to minimise span changes, and its channels track within 0.15 (from -20 to +60°C) to minimise zero shift with temperature. Close tolerancing of each channel to ±0.15 at 20°C facilitates barrier substitution.

If the bridge circuit is already earthed, a third barrier channel is needed; in practice this can be one half of another MTL755ac, Fig. 5. For extreme accuracy use three channels and an earth-free bridge, since the small errors due to barrier leakage tend to cancel.

4-wire constant-current circuits do not require matched barrier resistances, and can be protected more economically by two MTL761ac 2-channel barriers, Fig. 6. If the increase in loop resistance is too great, use two MTL755acs.

Slidewire displacement transducers

There are many solutions. Perhaps the simplest is that shown in Fig. 7, where an MTL760ac supplies power and brings back a unipolar signal. Other barriers that could be used include the MTL761ac, 765ac, 772ac, 778ac. Where polarity reversal or very high accuracy are required, use the techniques designed for strain-gauge bridges, below.

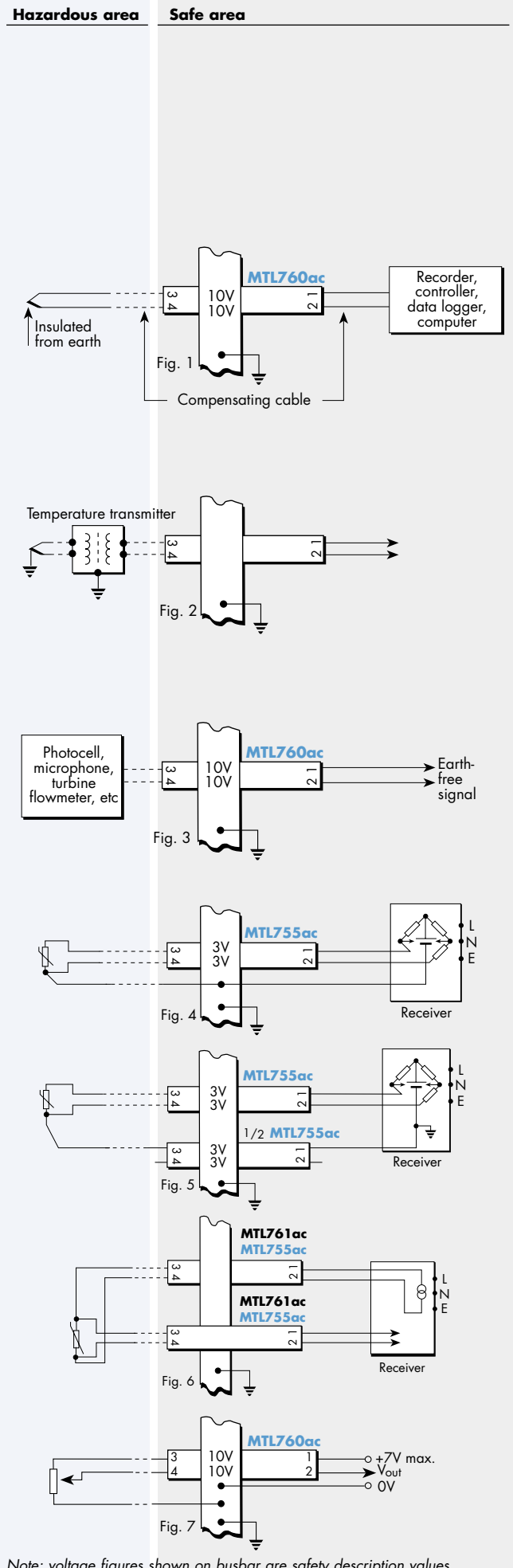

Note: voltage figures shown on busbar are safety description values.

BARRIERS FOR SENSORS

(continued)

ANALOGUE INPUTS, LOW LEVEL (continued)

Strain-gauge bridges

Fig. 8 shows an arrangement using two or three barriers, which is safe in IIC gases (system certificate no. Ex842125). With the MTL761ac, the circuit is powered from a 12V, 290 source; if the bridge resistance is 290, then the bridge voltage is 6V. If the MTL766ac is used, the source is 20V, 370, and provides a bridge voltage of 10V when the bridge resistance is 370.

Quite frequently there is a demand to monitor three load cells, and a possible circuit is shown in Fig. 9 (system certificate no. Ex842128). The two channels of each MTL766ac barrier are connected in parallel to reduce the source resistance, and provide 8V across the three 350 bridges. However, the higher energy present means that the system is safe in IIA and IIB gases only.

Weighing by load-cell is an application where the lower voltage drop of the MTL766Pac, compared to the MTL766ac, is a great advantage. In such applications, the MTL766Pac supplies power to the bridge while an MTL761Pac interfaces with the sensing and pick-off circuits. Using the two barriers in combination (see Fig. 10), the minimum voltages available in 350 bridge systems with a ±10V supply are as follows:-

- 1 bridge: 13.0V
- 2 bridges: 9.7V
- 3 bridges: 7.7V
- 4 bridges: 6.4V

Gas detectors, logic systems

Some devices require a high current at a low voltage, for example, 300mA at 2.3V for a typical gas detector. The low end-to-end resistance (18) of the 2-channel MTL758+, and its working voltage of 6V, make this barrier ideal for energising gas detectors, 5V logic systems, certain displays and similar equipment. The two channels can be used separately or in parallel as required, and the system remains safe in IIC gases if an MTL761ac is added to bring back the measurement.

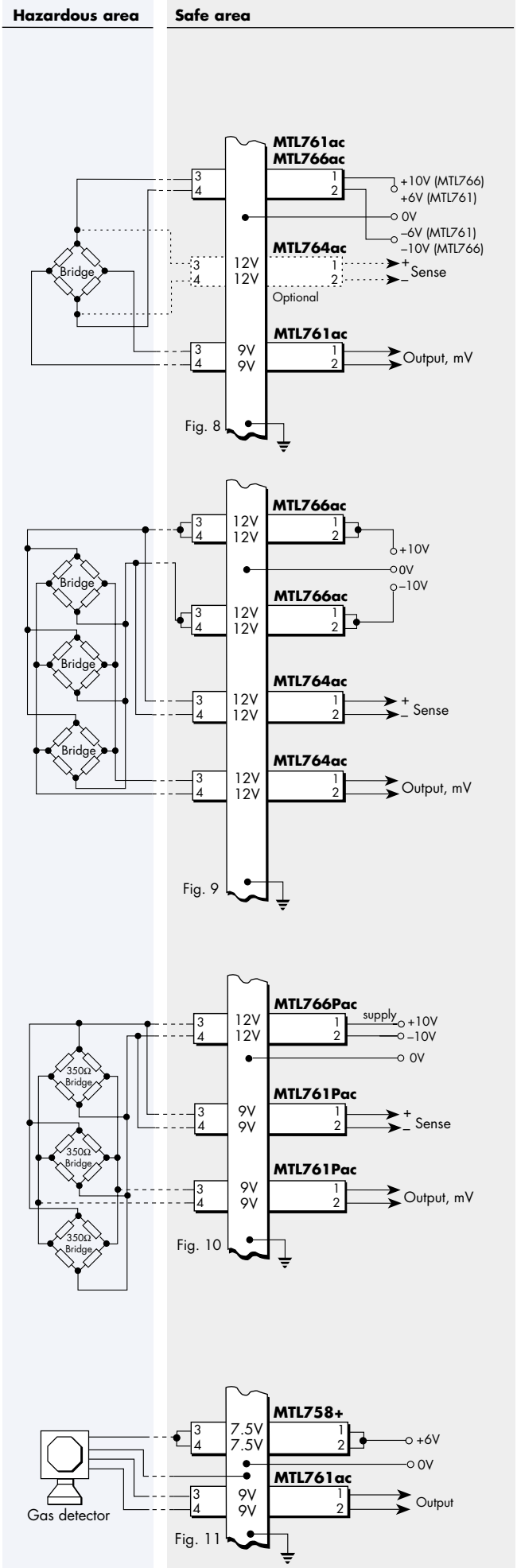

BARRIERS FOR TRANSMITTERS AND SWITCHES

ANALOGUE INPUTS, HIGH LEVEL

2-wire 4/20mA transmitters

If several transmitters are to be operated from a common dc supply, and this can be closely regulated (at 26V max), the MTL787S+ now beats the previously recommended MTL788+ by nearly half a volt, providing up to 12.9V at 20mA for a transmitter and its lines, as well as the usual 5V for the load, Fig. 12. Its return channel is more tolerant of errors during installation and fault finding, and it is safe with cables of much higher inductance. If the load requirement can be reduced, the voltage available for the transmitter will be greater.

If the supply can be closely regulated, and the transmitter is compatible with the higher power levels available from this barrier in IIC gas groups, the 2-channel MTL787SP+ is recommended. With a 26V supply it provides 14.6V at 20mA for a transmitter and lines as well as the usual 5V for the load, beating the MTL787S+ by 1.7V, Fig. 12.

The voltage available for the transmitter and its lines can be increased by converting the return current into a 1–5V signal before it passes through an MTL788+ barrier. The MTL788+ contains a 250 precision resistor for this purpose and makes 14.2V available, Fig. 13.

If greater voltage capability is required for the transmitter or the load, or the supply is not closely regulated, then the MTL702+ is a proven good solution, Fig. 14. This overvolt-protected barrier delivers 14V at 20mA for the transmitter and lines from a 22–35V supply, plus a quite exceptional 17V for the load, both voltages being increased by 2V if the supply is at least 24V. It will pass incoming communication signals of any frequency from a ‘smart’ transmitter but inherently cannot pass signals in the outgoing direction. Accuracy is high and current consumption is less than 60mA.

Where 2-way communication with ‘smart’ transmitters is required, there are two solutions. If the supply is closely regulated, choose the MTL787S+ (above). If it cannot be closely regulated, choose the MTL706+, Fig. 15. This overvolt-protected barrier – derived from the previously recommended MTL705+ – provides 15V at 20mA for the transmitter and lines from a 22–35V supply, plus 5V for the load. It is lower in cost than the MTL702+, is extremely accurate, has a standard safety description and consumes only 35mA. Note that the load resistor must be 250 \pm 5% and that terminal 3 is negative.

If the supply is poorly regulated, the 2-channel MTL707P+ provides a low cost solution for IIB applications, where its low end-to-end resistance makes 13V available for the transmitter and field cabling plus 5V for the load when powered from 24V dc, and its overvolt protection allows supply variations up to 35V dc, Fig. 16.

Fire and gas detection

Designed primarily for fire and gas detection systems, the lower maximum end-to-end resistance of the MTL722P+ (121 Ω) compared to the MTL722+ (185 Ω) can be an advantage (see Fig. 17). In addition, it may prove useful in other 18V dc systems.

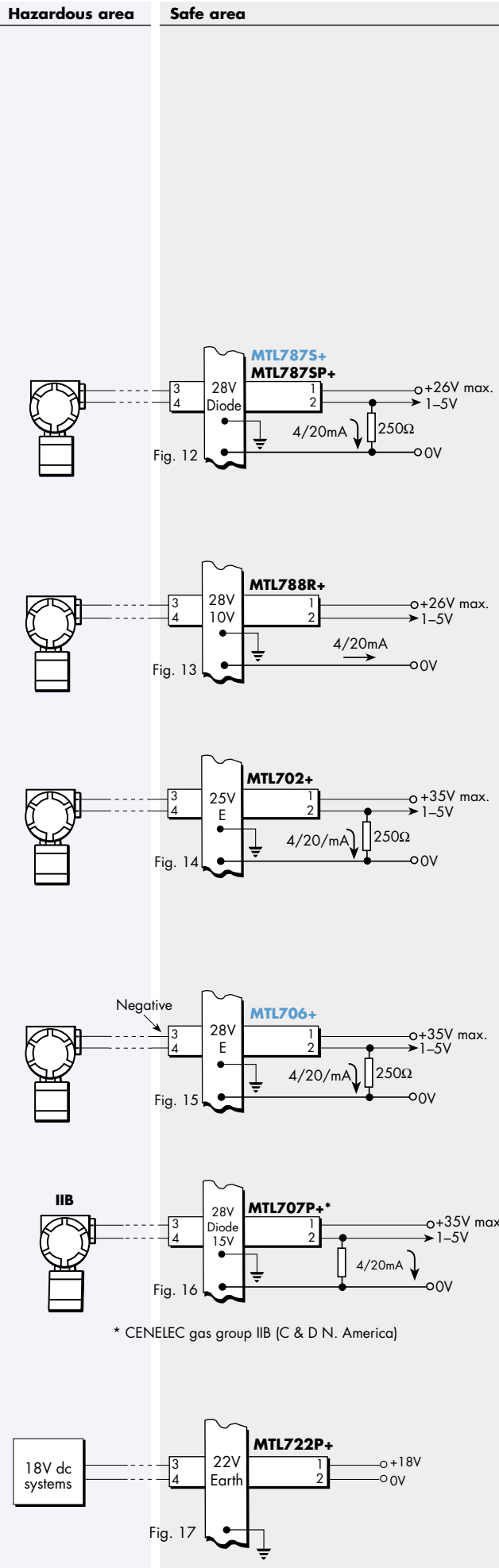

DIGITAL (ON/OFF) INPUTS

Switches

For switch-status transfer, Fig. 18, the MTL707+ is preferred for two reasons. First, the circuit fails safe if there is an earth fault on either line – i.e. the safe-area load de-energises. Second, the MTL707+ accepts up to 35V from poorly regulated power supplies without blowing its fuse: if the supply is well regulated, the MTL787S+ can be used, see Fig. 19.

In both cases, optimum power transfer with relays is achieved if the resistance of the load is made about equal to the combined resistance of the two channels. The relay coil should then be rated at about half the supply voltage.

Switches, data-loggers, logic systems

The MTL710P+ can be used for supplying power to low-voltage equipment in hazardous areas, such as data-loggers, switches and logic systems. Its low maximum end-to-end resistance of 42 Ω , compared to 85 Ω for the MTL710+, means it can typically supply more than 65mA current at 5V from an 8V supply (see Fig. 20). It also has the advantage of a higher working voltage (8V compared to 6V for the MTL710+).

The MTL715P+ functions similarly for 12V dc systems and can also be applied to multiple-switch and logic circuits where the additional power proves useful, Fig. 21.

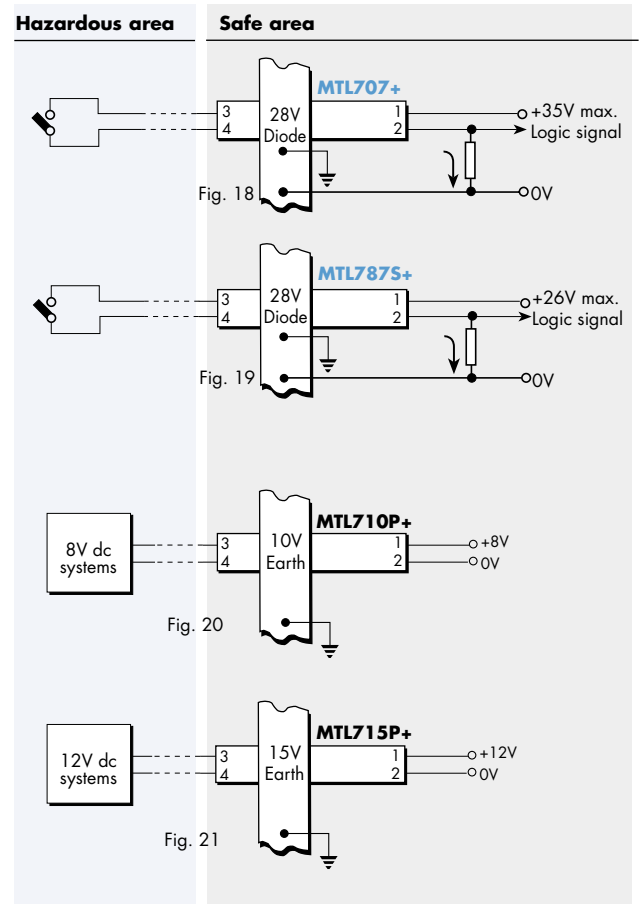

BARRIERS FOR CONTROL ELEMENTS

ANALOGUE OUTPUTS

Controller outputs – 4 to 20mA

In most cases the output current of a controller flows directly to its '0V' rail and the rail can be earthed at the busbar, Fig. 22. Occasionally the output circuit may be fully floating. In either event the 1-channel MTL728+ or half an MTL779+ provides the solution. Overvoltage protection is not required, since current limiting in the controller protects the fuse in the barrier. The voltage drop introduced by the barrier is 6.8V at 20mA.

The maximum voltage drop introduced by the MTL728P+ is only 5.1V at 20mA (compared to 6.8V for the MTL728+).

For IIB applications, the MTL728P+ can be replaced with the similarly designed 1-channel MTL729P+.

If the output circuit of the controller is separated from the '0V' rail by the control transistor, Fig. 23, a 2-channel barrier is necessary. The MTL787S+ is recommended, since its return channel can handle up to 25.5V, allowing the control signal to be turned off completely. The voltage drop introduced by the barrier is 8.1V at 20mA.

The maximum voltage drop introduced by the MTL787SP+ is only 6.4V at 20mA (compared to 8.1V for the MTL787S+). The barrier return channel can handle up to 24.5V, allowing the control signal to be turned off completely.

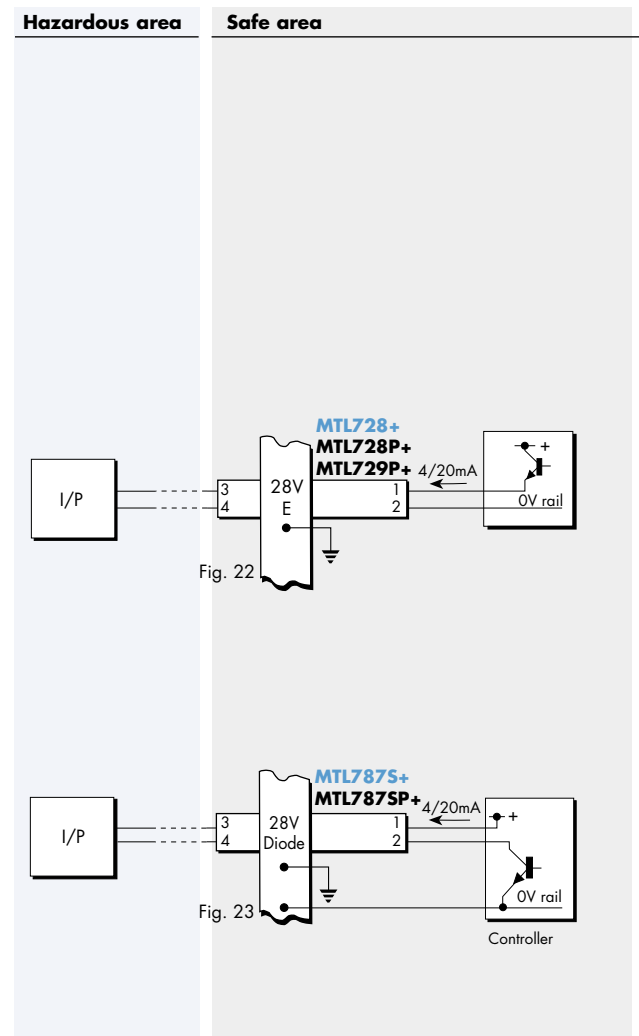

The MTL787S+ and MTL787SP+ are also suitable for controllers containing a resistor which enables the return current to be monitored for high-integrity operation, Fig. 24.

For IIB applications where a 2-channel barrier is needed (see above), the MTL707P+ can be used as, although the overvolt protection provided by this barrier is not necessary, the diode return channel and low voltage drop makes this an ideal replacement for the MTL787S+ or MTL787SP+ for IIB gas groups, Fig. 25.

DIGITAL (ON/OFF) OUTPUTS

Solenoids, alarms, LEDs

If the supply is well regulated, an MTL728+ (or half an MTL779+) can be used.

For IIC applications, the lower end-to-end resistance of the MTL728P+ can make a big difference to the overall loop design when driving higher-power solenoid valves, provided the power supply is well regulated, Fig. 26.

Should greater power be required for heavy-duty solenoids in IIB or IIA gases only ('IEC countries'; C & D in USA and Canada), use the two channels of the MTL779+ connected in parallel or consider the MTL3022 or MTL5022.

Similarly the MTL729P+ is ideal for powering high-power heavy-duty solenoid valves, in IIB gas group applications, providing a maximum usable output power of 0.78W at 24V, Fig. 26.

Most solenoid valves, alarms, light-emitting diodes (LEDs) and other on/off hazardous-area loads are best driven via an MTL708+ 1-channel barrier, with built-in overvolt protection, Fig. 27. The circuit fails safe with an earth fault on the live line and is unaffected by an earth fault on the earth return, while the barrier will accept up to 35V without blowing its fuse.

If the control switch is on earth, then a 2-channel barrier has to be used, Fig. 28, but be aware that an earth fault on the return line will energise the solenoid, whereas one on the live line does the opposite. If the supply is poorly regulated use the MTL707+ (or MTL707P+ for IIB gases). If it is well regulated use the MTL787S+ (or MTL787SP+).

Alternatively, for operational safety, use an MTL2000, 3000, 4000 or 5000 Series isolating interface unit.

Fieldbus applications

The MTL791 (Fig. 29) is a 2-channel barrier designed specifically for 31.25kbit/s fieldbus applications. Used with a suitable floating fieldbus power supply of up to 20V (such as that provided by the MTL5995 unit) it extends the range of fieldbus applications into hazardous areas. It is provided with an internal integral safe-area terminator*.

* 'Terminators' are used to terminate a fieldbus – see 'Bus systems' for details of the FBT1 DIN-rail mounting terminator.

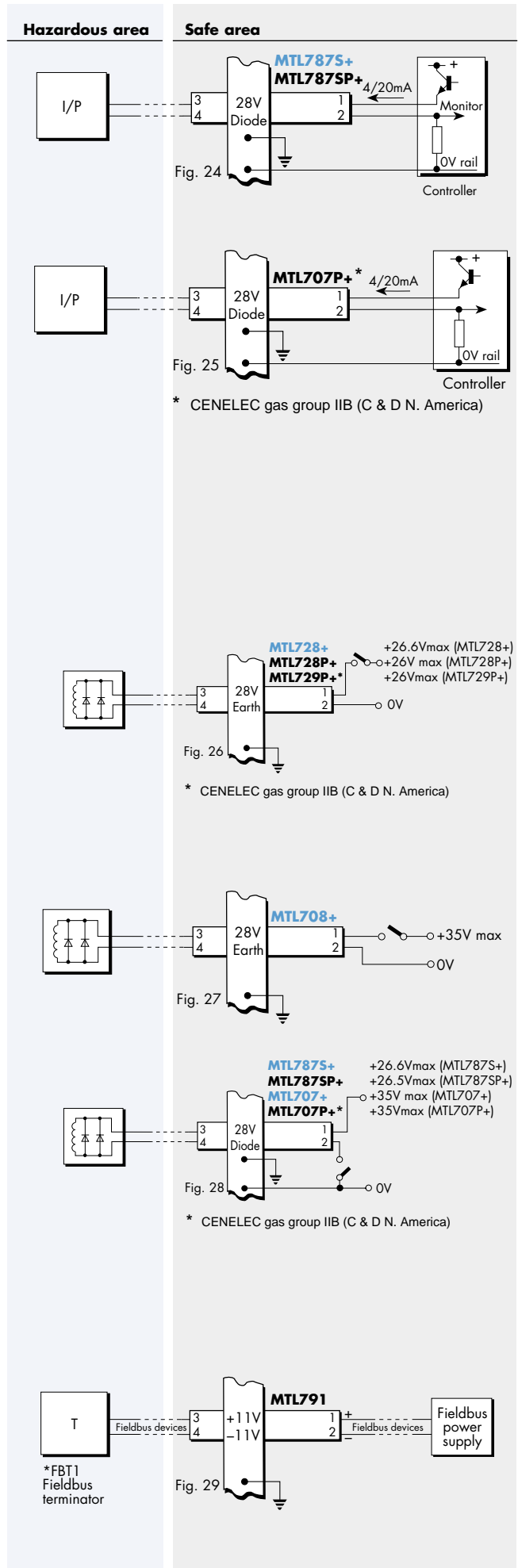

CABLE PARAMETERS AND PERMITTED COMBINATIONS

Barrier model number MTL	Number of single channels interconnected within hazardous area	Earth 1 return used?	Maximum permissible cable parameters					Matched power W (BASEEFA)
			BASEEFA (group IIC) 2			FM (groups A&B)		
			Capacitance μF	Inductance mH	L/R ratio $\mu\text{H}/$ or $\mu\text{H}/$	Capacitance μF	Inductance mH	
702+	1	Yes	0.17	2.2	46	0.17	2.2	0.78
706+	1	Yes	0.13	4.2	55	0.12	4.0	0.65
707+	Both	Yes	0.13	4.2	55	0.12	4.0	0.65
708+	1	Yes	0.13	4.2	55	0.12	4.0	0.65
710	1	Yes	3.0	0.95	72	3.0	1.0	0.50
710P	1	Yes	3.0	0.395	47	4.89	0.22	0.75
715	1	Yes	0.75	1.65	65	0.7	1.4	0.56
715P	1	Yes	0.75	0.32	36	1.04	0.23	1.09
722	1	Yes	0.26	1.75	46	0.2	1.4	0.81
722P	1	Yes	0.26	0.27	29	0.33	0.53	1.17
728	1	Yes	0.13	4.2	55	0.12	4.0	0.65
728P	1	Yes	0.13	2.47	42	0.16	2.86	0.83
751ac	1	Yes	1000	3.6	1450	1000	4.5	0.025
	2	Yes	1000	0.95	540	1000	1.2	0.05
		No	1000	3.6	725	1000	4.5	0.05
755ac	1	Yes	1000	0.46	165	1000	0.4	0.23
	2	Yes	1000	0.125	69	150	0.1	0.45
		No	40	0.46	70	150	0.1	0.45
	3	No	40	0.125	48	-	-	0.68
	4	Yes	40	0.035	31.25	-	-	0.92
		No	40	0.06	42	-	-	0.92
758	1	Yes	10	0.070	27	6.0	0.05	1.41
	2	Yes	10	0.013	10.5	6.0	0.02	2.82
760ac	1	Yes	3.0	0.95	72	3.0	0.9	0.50
	2	Yes	3.0	0.27	28	3.0	0.2	1.00
761ac	1	Yes	5.0	3.6	161	3.1	3.5	0.23
	2	Yes	5.0	0.95	60	0.4	1.0	0.45
		No	0.42	3.6	80	0.4	1.0	0.45
	4	Yes	0.42	0.20	26.39	-	-	0.90
		No	0.42	0.37	37.78	-	-	0.90
	6	Yes	0.42	0.085	14.39	-	-	1.35
		No	0.42	0.13	18.67	-	-	1.35
761Pac	2	Yes	0.42	13	214	0.43	14.4	0.11
764±	1	Yes	1.6	230	900	1.5	200	0.04
	2	Yes	1.0	60	345	1.0	60	0.08
764ac	1	Yes	1.6	230	900	1.5	200	0.04
	2	Yes	1.6	60	345	0.18	60	0.08
		No	0.2	230	450	0.18	60	0.08
765ac	1	Yes	0.75	1.65	65	0.7	1.3	0.56
	2	Yes	0.75	0.32	24.75	0.7	1.4	1.13
766ac	1	Yes	1.4	5.8	150	1.5	5.6	0.24
	2	Yes	1.4	1.5	58	0.18	1.5	0.48
		No	0.2	5.8	75	0.18	1.5	0.48
766Pac	2	Yes	0.2	0.34	30	0.22	0.20	0.94
767	1	Yes	0.75	1.65	65	0.7	1.7	0.56
	2	Yes	0.50	0.32	24.75	0.5	0.4	1.12
768	1	Yes	0.26	1.75	46	0.2	1.7	0.81
772ac	1	Yes	0.18	6.8	86.6	0.2	6.0	0.41
	2	Yes	0.18	1.75	34	0.2	1.8	0.81
778ac	1	Yes	0.13	16	106	0.12	14	0.33
	2	Yes	0.13	4.2	41	0.12	4.2	0.66
779	1	Yes	0.13	4.2	55	0.12	4.0	0.65
786	1 or 2	Yes	0.13	-	-	0.11	500	-
787 & 787S	Both	Yes	0.13	4.2	55	0.11	4.0	0.65
787SP	2	Yes	0.13	2.47	42	0.13	2.70	0.83
788 & 788R	Both	Yes	0.13	0.37	24	0.11	0.5	1.15
791	Both	No	0.27	0.35	31	0.24	0.31*	1.18
796	Both	Yes	0.16	1.9	34.5	0.13	2.0	0.82
			BASEEFA (group IIB) 2			FM (group C)		
707P	2	Yes	0.39	5	121	0.45	6.21	1.19
729P	1	Yes	0.39	5	121	0.49	6.25	1.19

System combination	BASEEFA system Cert. No.	Earth 1 return used?	BASEEFA Maximum permissible cable 2 parameters for group IIC (hydrogen)			Matched power W (BASEEFA)
			Capacitance μF	Inductance mH	L/R ratio $\mu\text{H}/$ or $\mu\text{H}/$	
1x715P 4x764ac	Ex92C2425	Yes	0.135	0.23	39.3	0.91
2 x 761 ac channels 2 x 764ac channels 2 x 766ac channels	Ex842125	Yes	0.2	0.24	11.6	1.01
4 x 761 ac channels 2 x 764ac channels	Ex842125	Yes	0.2	0.2	12.7	0.98
4x761Pac channels 2x766Pac channels	Ex92C2424	Yes	0.18	0.17	18.4	1.17
2 x 764ac channels 4 x 766ac channels	Ex842128	Yes	0.2	0.28	11	1.04
758 + 761ac	Ex872392	Yes	0.42	0.013	10.5	3.27
			BASEEFA Maximum permissible cable parameters for group IIB (not safe for group IIC)			
4 x 764ac channels 4 x 766ac channels	Ex842128	Yes	0.6	1.1	32.6	1.12
2 x 768 channels	Ex842114	Yes	0.78	1.8	70	1.62
2 x 768 channels	Ex842114	Yes	0.39	1.8	46.6	1.62
Any number of 786 channels						
2 x 779 channels	Ex842114	Yes	0.39	4.3	83	1.3
2 x 779 channels	Ex842114	Yes	0.39	4.3	55.6	1.3
Any number of 786 channels						

* L/R = 31 $\mu\text{H}/$

The tables give the maximum permitted cable parameters (including cable and load) for hazardous-area circuits in group IIC and IIB gases. However, the tables are by no means exhaustive and for full details of other safe combinations, consult either BASEEFA system certificates Ex832469, Ex92C2374 or Ex92C2376 or MTL. The MTL702 is covered by BASEEFA system certificate Ex842308, and the MTL706 by Ex872513.

In practice cable parameters rarely present a problem, as all cables normally used for instrument interconnection have L/R ratios below 25 $\mu\text{H}/$ and capacitance below 200pF per metre.

Note 1 If values are not quoted for when an earth return is not used, those for an earth return ('Yes' in the table) can be used.

Note 2 For most practical purposes, the values of the parameters for groups IIB and IIA are respectively three and eight times the values for group IIC. Values for IIA are 2.6 times those for IIB.

Note 3 The maximum power that can be drawn from the barrier combination under fault conditions. Used for assessing the temperature classification of 'simple' hazardous-area apparatus. For FM permitted combinations, refer to MTL document SCI-88 (via FM ref 1H8A1.AX).